

OCTEON® Plus CN55XX 4 to 6-Core MIPS64 Storage Processors

Product Brief



OVERVIEW

The OCTEON® Plus CN55XX family of Multi-Core Storage Services processors targets low-end to mid-range intelligent storage array, storage networking, and storage appliance applications. The family includes six different software-compatible parts, with four to six cnMIPS64 cores on a single chip that integrate high-density, high-bandwidth standard interfaces along with the most advanced storage security, RAID, and storage application acceleration to deliver a scalable platform for developing next-generation storage products.

FEATURES

- 4-6 cnMIPS cores, up to 700 MHz on a single chip
 - Up to 8.4 Billion MIPS64 instructions per second
 - 1MB L2 Cache
- High-density, high-bandwidth serial I/O for storage and system connectivity
 - 16 high-speed SERDES, flexibly configured in blocks of 4
 - Flexible combinations of PCI Express x4, x8, XAUI (10GbE), SGMII (GbE)
- Complete hardware acceleration for storage, networking, and security
 - Support for AES-XTS IEEE1619 Data at Rest and IPsec (3DES, AES-GCM, AES up to 256), SHA-1, SHA-2 up to SHA-512, RSA up to 8192, DH
 - Compression/decompression engine with up to 1.0 GBps throughput and highest compression ratios
 - RAID/XOR Acceleration coprocessor for RAID 5 and 6
 - Key Reliability/Availability/Serviceability features

Optimized power consumption: 8W – 20W

- Package: 35 x 35 mm 1217 FCBGA

BENEFITS

- Powerful DMA engines for maximum I/O and system performance
- Industry leading performance
 - Virtual IOPS up to 1.5M
 - iSCSI to disk IOPS up to 140K
- Integrated DDR2 memory controller up to DDR2-800 with ODT features
 - Increased memory performance with simplified layout and timing
- Standard OS and C/C++ based programming model
- Linux, VxWorks
 - Allows for quick porting and new development
 - No proprietary tools or micro-coding
- Software compatible
 - Single software code based across performance points ranging from 1 Gbps iSCSI/FC to 4 Gbps FC
- Highest performance and integration for next-generation storage equipment requirements

OCTEON® Plus CN55XX - Block Diagram

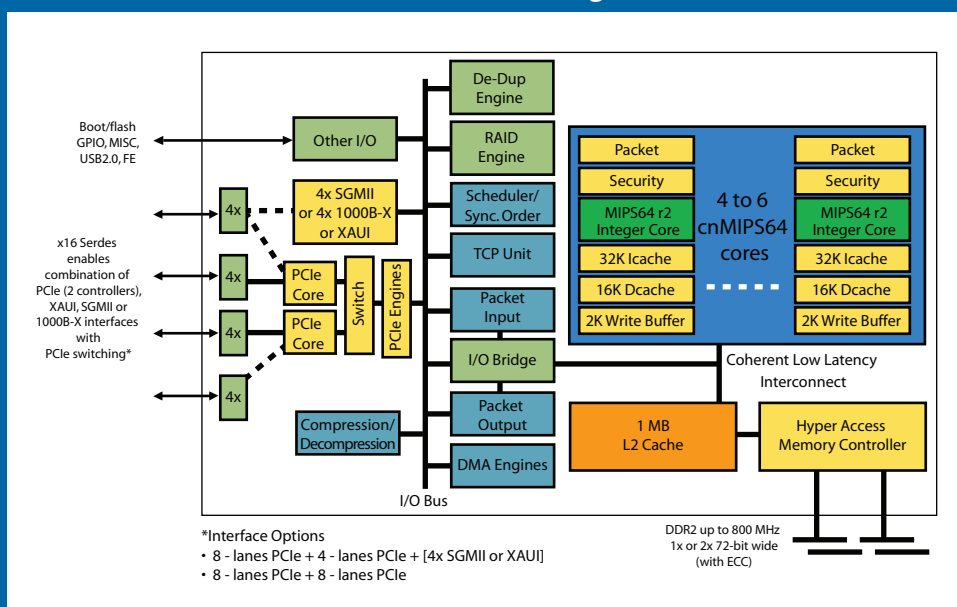

OCTEON[®] Plus CN55XX 4 to 6-Core MIPS64 Storage Processors

Product Brief

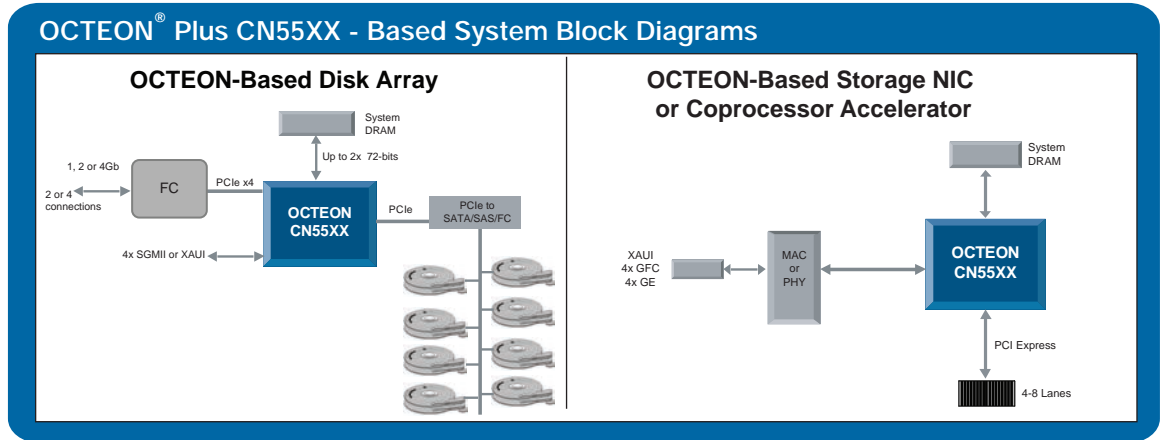

APPLICATIONS

- Next-generation storage encryption appliance
- Storage bridge - FC to iSCSI
- Storage archival appliance with advanced de-duplication
- Network Attached Storage (NAS) appliance
- 10G iSCSI host bus adapter
- Storage compression appliance
- Intelligent storage router
- RAID, TCP/IP iSCSI, storage security, offload card

SOFTWARE SUPPORT

- Cavium SDK includes:
 - Up to 6-way SMP LINUX support
 - Cavium Simple Executive for data plane applications
 - Complete GNU tool-chain, GDB, DDD, and viewzilla for tuning
 - Optimized C libraries for security, regular expression, de/compression processing offload
 - Support for run-to-completion or pipelined software models
- Complete production quality development toolkits for TCP, IP, IPSec, iSCSI, RAID, and others
- Comprehensive ecosystem support
 - Popular third-party Operating systems and toolchains, including MontaVista Linux, Wind River VxWorks
 - Linux and Windows host driver
 - Appliance motherboards from leading ODMs
- MIPS64/32 support enables thousands of MIPS and other C/C++ applications to be easily ported to OCTEON

OCTEON[®] Plus CN55XX - Product Family

Device	cnMIPS cores	Performance	Option		L2 Cache	Networking Interfaces	PCI-Express Controllers	Memory IO w/ECC	Package
		Max. Available Instructions Per Second	S S P	S P					
CN5530	4	5.6B	Y	Y	1MB	4x SGMII or XAUI	2x [x4 or x8 Lanes]	DDR2 up to 800 MHz 1x or 2x 72-bits wide	1217 FCBGA
CN5534	6	8.4B	Y	Y					

Device Options:

Device Speed Grade (500LP = 500 MHz Low Power, 600LP = 600 MHz Low Power, 600 = 600 MHz, 700 = 700 MHz)
Option Code for device family listed below:

SSP = Secure Storage Processor: Includes RAID, encryption, compression, networking, TCP acceleration and QoS
SP = Storage Processor: Includes RAID, compression, networking, TCP acceleration and QoS